



TurboDrag Pump

HiPace 80

HiPACE

Table of contents

1	About this manual	3
1.1	Validity	3
1.2	Conventions	3
2	Safety	5
2.1	Safety precautions	5
2.2	Proper use	6
2.3	Improper use	6
3	Transport and storage	7
3.1	Transport	7
3.2	Storage	7
4	Product description	7
4.1	Product identification	7
4.2	Function	7
4.3	Range of application	8
5	Installation	9
5.1	Set-up	9
5.2	Preparatory work	9
5.3	Assembly	9
5.4	Connections to the turbopump	12
6	Operation	17
6.1	Commissioning	17
6.2	Operation modes	18
6.3	Function description	18
6.4	Monitoring of the operation conditions	19
6.5	Switching off and venting	19
7	Maintenance / replacement	20
7.1	Maintenance intervals and responsibilities	20
7.2	Replacing the integrated power supply	20
7.3	Replacing the operating fluid reservoir	21
7.4	Replacing the electronic drive unit	23
8	Decommissioning	24
8.1	Shutting down for longer periods	24
8.2	Re-starting	24
8.3	Disposal	24
9	Malfunctions	25
9.1	Rectifying malfunctions	25
10	Service	26
11	Spare parts HiPace 80	27
12	Accessories	28
13	Technical data and dimensions	29
13.1	General	29
13.2	Technical data	30
13.3	Dimensions	31
	Manufacturer's Declaration	32

1 About this manual

1.1 Validity

This operating manual is for customers of Pfeiffer Vacuum. It describes the functioning of the designated product and provides the most important information for safe use of the unit. The description follows applicable EU guidelines. All information provided in this operating manual refer to the current state of the product's development. The documentation remains valid as long as the customer does not make any changes to the product.

Up-to-date operating instructions can also be downloaded from www.pfeiffer-vacuum.net.

Applicable documents

HiPace 80	Operating instructions
Safety information for vacuum pumps "Safety Guide"	PT 0300 BN*
Operating instructions "Electronic drive unit TC 110"	PT 0204 BN*
Manufacturer's declaration	Part of this document
Operating instructions for accessories	see section "Accessories"*

*also available via www.pfeiffer-vacuum.net

For information about other certifications, if applicable, please see the signet on the product or:

- www.tuvdotcom.com
- TUVdotCOM-ID 0000021320

1.2 Conventions

Safety instructions

The safety instructions in Pfeiffer Vacuum operating manuals are the result of risk evaluations and hazard analyses and are oriented on international certification standards as specified by UL, CSA, ANSI Z-535, SEMI S1, ISO 3864 and DIN 4844. In this document, the following hazard levels and information are considered:

DANGER
<p>Immediate danger Death or very severe injuries can occur.</p>
WARNING
<p>Possible danger Injuries or severe property damages can occur.</p>
CAUTION
<p>Possible danger Injuries or property damages can occur.</p>
NOTE
<p>Command or note Command to perform an action or information about properties, the disregarding of which may result in damage to the product.</p>

Pictograph definitions



Prohibition of an action or activity in connection with a source of danger, the disregarding of which may result in serious accidents.



Warning of a displayed source of danger in connection with operation of the unit or equipment.



Command to perform an action or task associated with a source of danger, the disregarding of which may result in serious accidents.

Instructions in the text

→ Work instruction: here you have to do something.

Abbreviations used

DCU: Display and operating unit
HPU: Handheld programming unit
TC: Electronic drive unit for turbopump
OPS: Integrated Power supply

Symbols used

The following symbols are used consistently throughout the diagrams:

- Ⓜ High vacuum flange
- Ⓦ Fore-vacuum flange
- Ⓥ Vacuum flange of the backing pump
- Ⓣ Exhaust flange of the backing pump
- Ⓩ Electrical connection

2 Safety



NOTE

Duty to inform

Each person involved in the installation, operation or maintenance of the vacuum pump must read and observe the safety-related parts of these operating instructions.

- Absolute observe the safety information for vacuum pumps (PT 0300 BN) !
- The operator is obligated to make operating personnel aware of dangers originating from the vacuum pump, the pumped medium and the entire system.



NOTE

Installation and operation of accessories

Pfeiffer Vacuum pumps can be equipped with a series of adapted accessories. The installation, operation and maintenance of connected devices are described in detail in the operating instructions of the individual components.

- For information on order numbers of components, see "Accessories".
- Use original accessory parts only.

2.1 Safety precautions



WARNING

Ensure safe electrical installation

Safe operation after installation is the responsibility of the operator.

- Do not independently modify or change the pump and electrical equipment.
- Make sure that the system is integrated in an emergency off safety circuit.
- Consult Pfeiffer Vacuum for special requirements.



WARNING

Danger of electric shock

In case of defect, the parts connected to the power supply are under voltage.

- Always keep the mains connection freely accessible so you can disconnect it at any time.



NOTE

Checking the safety system against excess rotation speed

To provide the functioning of the integrated safety system for avoiding excess rotation speed, the pump must run-up from the standstill at least once a year.

- Switch off the pump and await the complete standstill (rotation speed = 0 Hz).
- Run-up the pump according to this operating instructions.

- Always ensure a safe connection to the protective earthing conductor (PE, protection class I).
- Do not loosen any plug connection during operations.
- Wait for the rotor to reach standstill before performing work on the high vacuum flange.
- Keep leads and cables well away from hot surfaces (> 70 °C).
- Never fill or operate turbopump with cleaning agent.
- The unit has been accredited with protection class IP 30. When installing into ambient conditions, which afford other protection classes, the necessary measures must be taken.

2.2 Proper use



NOTE

CE conformity

The manufacturer's declaration becomes invalid if the operator modifies the original product or installs additional components!

→ Following installation into a plant and before commissioning, the operator must check the entire system for compliance with the valid EU directives and reassess it accordingly.

- The vacuum pump may only be used to generate a vacuum.
- Only operate the turbopump with an approved backing pump.

2.3 Improper use

Improper use will cause all claims for liability and guarantees to be forfeited. Improper use is deemed to be all use for purposes deviating from those mentioned above, especially:

- Pumping of corrosive or explosive media.
- Pumping of condensing vapors.
- Operation with improper high levels of gas loads.
- Operation with improper high fore-vacuum pressures.
- Operation with improper gas mode.
- Operation with improper high levels of insulated heat input.
- Venting with improper high venting rates.
- The operation of the devices in potentially radioactive areas.
- The operation of the devices in systems where the turbopumps are subjected to impact-like stress and vibrations or the effect of periodically occurring forces.
- The use of accessories, which are not named in this manual.



NOTE

Warranty seal

The product is sealed at the factory. Damaging or removal of the seal leads to the loss of liability and warranty entitlements.

→ Do not open the product within its warranty period!

→ For process-related shorter maintenance intervals please contact the Pfeiffer Vacuum Service.

3 Transport and storage

3.1 Transport

- Reuse the transport container. Vacuum pumps should be transported or shipped in the original packing only.
- Only remove the protective covers from the high vacuum and the fore-vacuum side immediately before connection.
- Keep the original protective covers.
- Always transport the turbopump in an upright position.

3.2 Storage

- Close the flange openings by using the original protective covers.
- Close further connection ports by using the corresponding protective covers.
- Store the pump only indoors at temperatures between -25 °C and +55 °C.
- In rooms with moist or aggressive atmospheres, the pump must be airproof shrink-wrapped in a plastic bag together with a bag of desiccant.

4 Product description

4.1 Product identification

Pump features

Characteristics	HiPace 80		
HV flange	DN 63 ISO-K	DN 63 CF	DN 40 ISO-KF
Flange material	Aluminium	Stainless steel	Aluminium

To correctly identify the product when communicating with Pfeiffer Vacuum, always have the information from the rating plate available.



Fig. 1: Example for a rating plate

Scope of delivery

- Turbopump with electronic drive unit
- Integrated power supply
- Protective cover for the high vacuum and the fore-vacuum flange
- Operating instructions

4.2 Function

The turbopumps HiPace 80 form a complete unit together with the electronic drive unit. The voltage is supplied via the integrated power supply pack.

Brigdes are closed in the connecting plug of the OPS. So the pump can run up at once after establishing the mains supply.

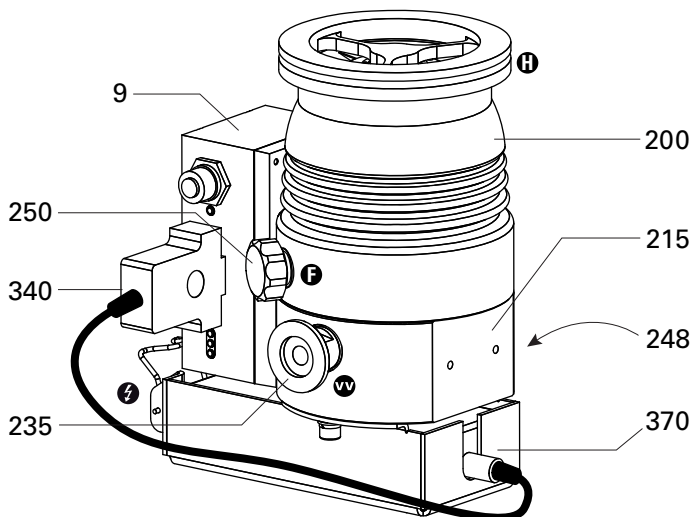

Fig. 2: View of HiPace 80 with TC 110 and OPS 70

9	Electronic drive unit TC 110	235	Fore-vacuum connection	340	Connecting plug
200	Pump housing	248	Sealing gas connection	370	Power supply OPS 70
215	Pump lower part	250	Venting connection		

Cooling

- Convection cooling
- Air cooling (optional)

In the case of excess temperature the electronic drive unit reduces the drive power automatically. Depending on the application and the HiPace different cooling variants are selectable.

Rotor bearing

Hybrid bearing TurboDrag pump

- High vacuum side: maintenance-free permanent magnetic bearing.
- Fore-vacuum side: ceramic ball bearing.

Drive

Electronic drive unit TC 110

4.3 Range of application

The pump HiPace 80 must be installed and operated under the following ambient conditions:

Installation location	weather protected (indoors)
Protection category	IP 30
Protection class	I
Temperature	+5 °C to +30 °C with convection cooling without gas load +5 °C to +35 °C with air cooling
Relative humidity	max. 80 %, at T ≤ 31 °C, up to max. 50% at T ≤ 40 °C
Atmospheric pressure	77 kPa - 106 kPa
Installation altitude	2000 m max.
Degree of pollution	2
Permissible surr. magnetic field	≤ 3 mT
Overvoltage category	II
Connection voltage power supply	90 - 265 V AC

5 Installation



DANGER

Danger from the turbopump being torn-off

In case of sudden blocking of the rotor, torques of up to 620 Nm can occur, which can lead with incorrect attachment to tearing the turbopump off. The energy released thereby can hurl the entire pump or fragments from their inside around the area. This can cause severest injuries (possibly resulting in death) and large property damage.

- Precisely follow installation instructions.
- Only use Pfeiffer Vacuum original components (accessories) for installation.



WARNING

Ensure safe electrical installation

Safe operation after installation is the responsibility of the operator.

- Do not independently modify or change the pump and electrical equipment.
- Make sure that the system is integrated in an emergency off safety circuit.
- Consult Pfeiffer Vacuum for special requirements.



NOTE

Installation and operation of accessories

Pfeiffer Vacuum pumps can be equipped with a series of adapted accessories. The installation, operation and maintenance of connected devices are described in detail in the operating instructions of the individual components.

- For information on order numbers of components, see "Accessories".
- Use original accessory parts only.

5.1 Set-up

When installing the pump, observe the following conditions:

- The ambient conditions specified for the area of use.
- The pump may be fastened to the floor only after consultation with Pfeiffer Vacuum.
- It is not allowed to operate the device in systems where impact-like stresses and vibrations or periodically forces occur.

5.2 Preparatory work

- Ensure sufficient cooling for the turbopump.
- Where magnetic fields > 3 mT are involved, a suitable shielding must be used. Check installation location and consult Pfeiffer Vacuum if needed!
- The maximum permissible rotor temperature for the turbopump is 90 °C. If high temperatures arise for process reasons, the radiated heat input must not exceed 0.9 W. Install suitable screening sheets, if necessary (design information on request).

5.3 Assembly

- Ensure the greatest possible cleanliness when installing any high vacuum parts. Unclean components prolong the pump-down time.
- All flange components must be grease-free, dust-free and dry at installation.
- The operating fluid reservoir is already installed and filled for the turbopump Hi-Pace 80.

Earthquake safety

An earthquake can result in contact with the safety bearings. All forces occurring hereby are safely absorbed by the properly installed flange connections.

→ The vacuum chamber must be secured by the customer against shifting and tipping.

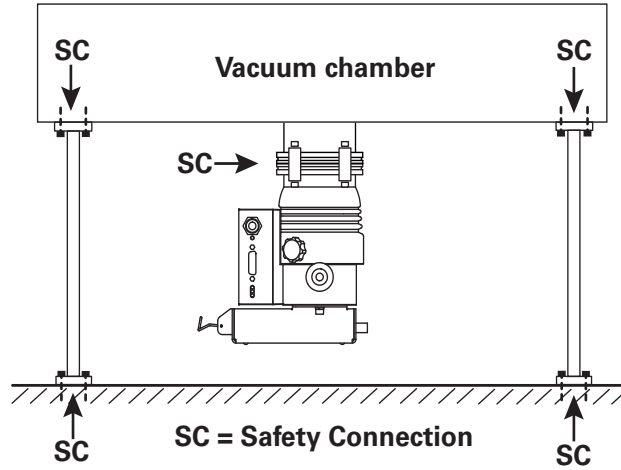

Fig. 3: Example: How to secure against shifting and tipping by external tremors

Use of a splinter shield or protection screen

The installation of a Pfeiffer Vacuum centering ring with splinter shield or protection screen in the high vacuum flange protects the turbopump against foreign bodies coming from the recipient. The volume flow rate is reduced as followed.

	Reduced volume flow rate in %			
	H ₂	He	N ₂	Ar
Splinter shield DN 40	6	9	17	18
Splinter shield DN 63	3	6	15	16
Protection screen DN 63	1	1	4	4

Vibration damper



DANGER

Danger from the turbopump and vibration damper being torn-off

In case of sudden blocking of the rotor, an applied vibration damper cannot compensate any of the occurring forces. There is a danger of the turbopump being torn-off and thereby resulting severest injuries and property damages. Applicable safeguards must be taken to compensate possible occurring torques.

→ Definitely consult with Pfeiffer Vacuum.

→ Do not exceed the max. permissible temperature at the vibration damper (100° C).

Mounting orientation

When using dry backing pumps Pfeiffer Vacuum HiPace pumps are designed for installation in any orientation.

- Support pipes in front of the vacuum pump or remove them. No force from the pipe system may be exerted on the fixed pump.
- To avoid contamination via the fore-vacuum line when using oil-sealed backing pumps the fore-vacuum flange should always point vertically downward ($\pm 25^\circ$).

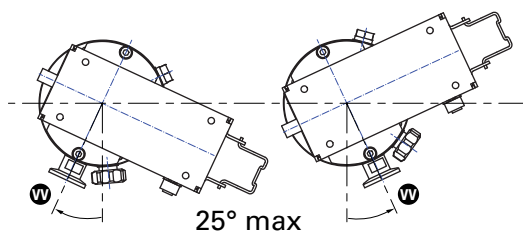

Fig. 4: Recommended orientation of the fore-vacuum flange

The maximum axial loading capacity of the high vacuum flange is 200 N (equals 20 kg). A one-sided load on the high vacuum flange is not permitted.

Installing the high vacuum flange

In the case the rotor suddenly blocks, the torques arising from the system and the high vacuum flange must be absorbed. Only the components listed in the following can be used to fasten the turbopumps to the high vacuum flange. The components for installing the turbopumps are special designs of Pfeiffer Vacuum. Observe the minimum strength of 170 N/mm^2 for the flange material.



NOTE

Mounting of ISO flanges

If the rotor suddenly blocks the connection of high vacuum flanges of types ISO-KF or ISO-K can lead to twisting despite proper installation.

- The tightness of the high vacuum flange is not at risk thereby.

Installation of ISO-KF flange with ISO-KF flange

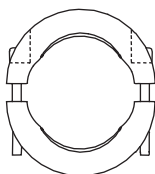

For the installation of the flange connections the following components are available:

- The valid mounting kit of the Pfeiffer Vacuum accessories programme.
- A protective screen or splinter shield can optionally be used.

→ Mind that the sealing surfaces are not damaged.

→ Flange the turbopump with the clamping ring.

→ Tightening torque: 3,7 Nm.

Installation of ISO-K flange with ISO-K flange

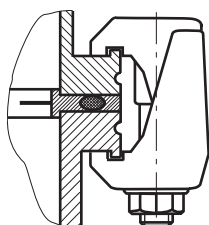

For the installation of the flange connections the following components are available:

- The valid mounting kit of the Pfeiffer Vacuum accessories programme.
- A protective screen or splinter shield can optionally be used.

→ Mind that the sealing surfaces are not damaged.

→ Connect the flanges according to the drawing and with the component parts of the mounting kit.

→ Use the required number of **4** claw clamps.

→ Tighten the claw clamps crosswise in three steps.

→ Tightening torque: 5, 15, 25 \pm 2 Nm

Installation of ISO-K flange with ISO-F flange

For the installation of the flange connections the following components are available:

- The valid mounting kit of the Pfeiffer Vacuum accessories programme.
- A protective screen or splinter shield can optionally be used.

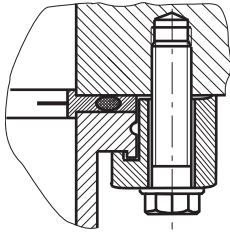

- Mind that the sealing surfaces are not damaged.
- Connect the flanges according to the drawing and with the component parts of the mounting kit.
- Use the required number of **4** claw grips.
- Tighten the claw grips crosswise in three steps.
- Tightening torque: 3, 10, 16 ±1 Nm.

Installation of CF-flanges



NOTE

Preservation of sealing capacity

Observe the following to preserve sealing capacity:

- Touch seals only with gloves.
- Make sure sealing lips are undamaged.

The connection types for installation of CF to CF flange are "stud screw and blind hole" as well as "hex screw and through hole". The following elements are required:

- The valid mounting kit of the Pfeiffer Vacuum accessories programme.
- A copper seal
- A protective screen or splinter shield can optionally be used.

Stud screw and blind hole

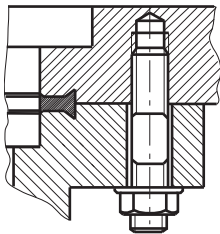

- If used: Insert protective screen or splinter shield with the clamping lugs downward into the high vacuum flange.
- Place the seal exactly in the hollow.
- Connect the flange using **8** stud screws (M8) with washers and nuts and tighten circularly with a torque of 22 ±2 Nm. After this, check the torque, since flowing of the sealing material may make it necessary to tighten the screws.

Hexagon screw and through hole

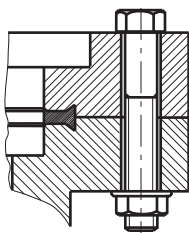

- If used: Insert protective screen or splinter shield with the clamping lugs downward into the high vacuum flange.
- Place the seal exactly in the hollow.
- Connect the flange using **8** hex screws (M8) with washers and nuts and tighten circularly with a torque of 22 ±2 Nm. After this, check the torque, since flowing of the sealing material may make it necessary to tighten the screws.

5.4 Connections to the turbopump

Electronic drive unit

- TC 110 SD in standard version
- TC 110 PB for Profibus linking
- TC 110 E74 based on SEMI E74

Detailed description for function, configuration and operation with the respective connection panel are given in the specific operating instructions for the electronic drive unit.

Connections diagram

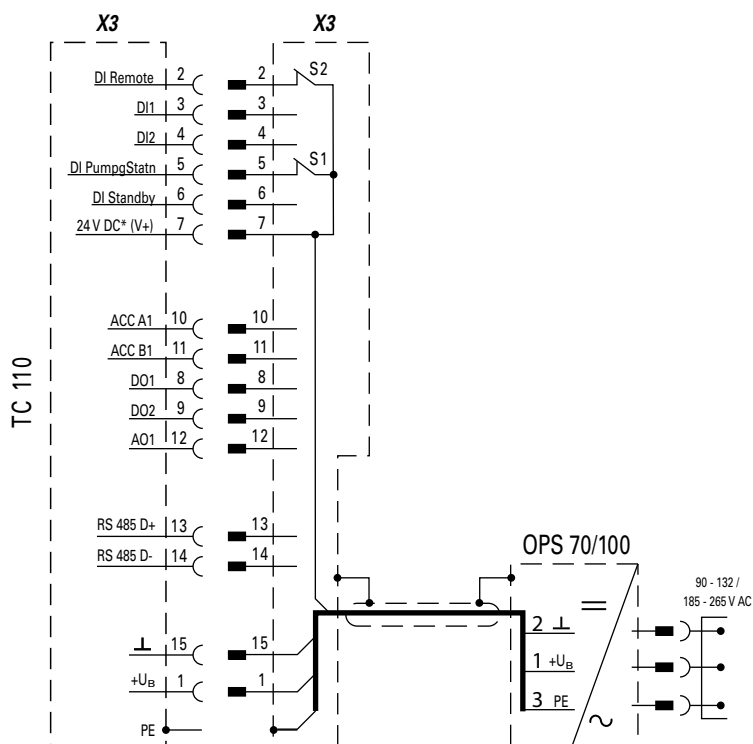

Bridges are closed in the connecting plug of the OPS. So the pump can run up at once after establishing the mains supply.

Accessory connection

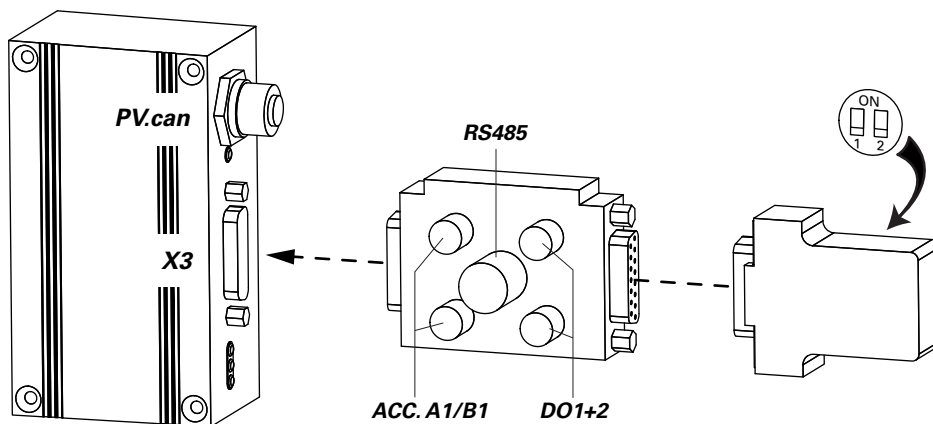

Fig. 5: Example: Connections on the electronic drive unit TC 110 with adapter TCS 12



NOTE

Accessory connection on the TC 110 with OPS 70

Connection and configuration of Pfeiffer Vacuum accessory units to the electronic drive unit TC 110 with integrated power supply is only possible by using respective adapters and after deactivation of the remote priority.

- ➔ Remove bridges in the connecting plug via DIL switches S1 and S2.
- ➔ Configure the preferred accessory output via RS485 using a Pfeiffer Vacuum display and control unit or a PC.
- ➔ Consider the operating instructions "Electronic Drive Unit TC 110"



NOTE

Accessory connection to an electronic drive unit in special design

Differing to the standard model, drive units in special design (e.g. Profibus panel) can be equipped with accessory connections.

- Refer to the operating instructions of the respective electronic drive unit.
- Connect the control lead of the accessory directly to the electronic drive unit.
- Configure the preferred accessory output via RS485 using a Pfeiffer Vacuum display and control unit or a PC.

Connecting the fore-vacuum side

Recommendation: As backing pump, use a dry-compressing vacuum pump or a rotary vane pump from the Pfeiffer Vacuum programme. The backing pump must generate a vacuum pressure of ≤ 5 mbar.



DANGER

Voltage-bearing elements

Danger to life from electric shock.

- The electrical connection can be carried out only by trained and authorised electricians.
- Ensure the system is adequately earthed.



WARNING

Damage to health due to poisonous gases

Process gases can damage health and contaminate the environment.

- Safely lead away the gas emission from the backing pump!
- Observe all safety recommendations of the gas producer.

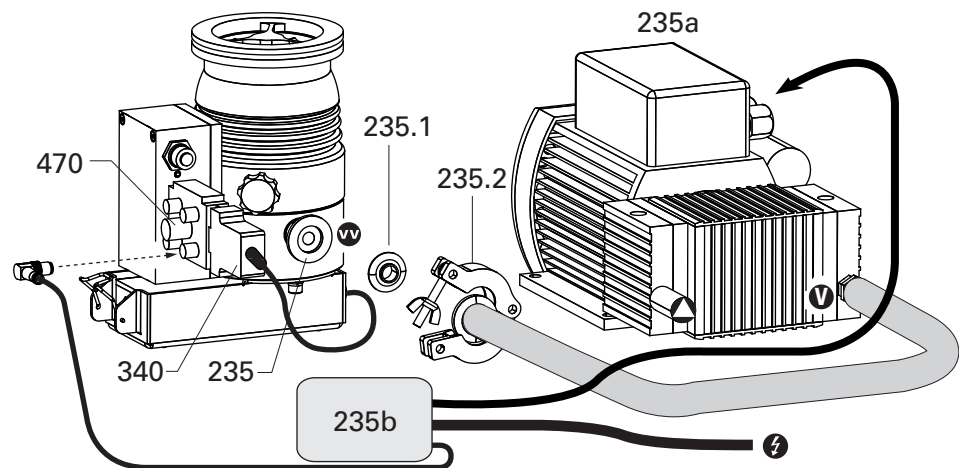

Fig. 6: Connecting the backing pump

- | | | |
|-----------------------------|----------------------|---------------------|
| 235 Fore-vacuum connection | 235.1 Centering ring | 340 Connecting plug |
| 235a Backing pump | 235.2 Clamping ring | 470 Adapter TCS 12 |
| 235b Backing pump relay box | | |

- With rigid pipe connections: Install bellows for attenuation of vibrations in the connection line.
- Connect the fore-vacuum line with small-flange components or threaded hose couplings. Do not narrow the free cross section of the fore-vacuum flange!
- The backing pump is connected electrically via a relay box.
- Plug in and fix the accessory's control lead to a free connection port on the connecting cable or adapter of the electronic drive unit.

- Establish the mains supply for the relay box according to the accessory operating instructions.
 - Observe the valid supply voltage of the backing pump.
- Make the settings and control via the interfaces of the TC 110.

Air cooling

Turbopumps with the electronic drive unit TC 110 (24 VDC) may be operated with air cooling up to an ambient temperature of +35 °C.

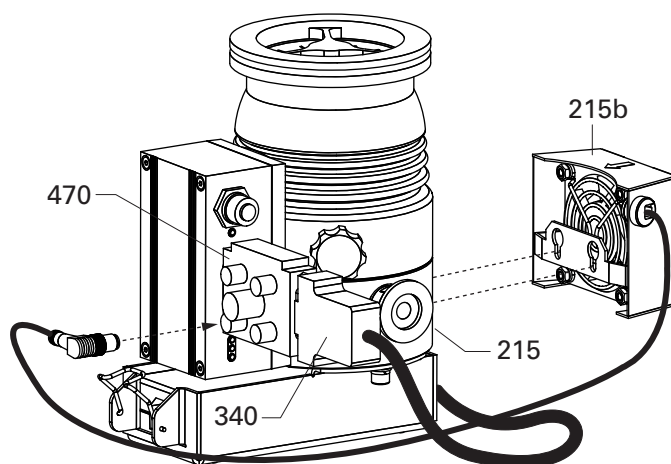

Fig. 7: Connecting the air cooling unit

215	Pump lower part	340	Connecting plug
215b	Air cooling unit	470	Adapter TCS 12

- Fix the Pfeiffer Vacuum air cooling unit to the holes of the turbopump using two screws.
- Plug in and fix the accessory's control lead to a free connection port on the connecting cable or adapter of the electronic drive unit.
- Make the settings and control via the interfaces of the TC 110.

Venting valve

The Pfeiffer Vacuum venting valve is used for automatic venting in case of shutdown or power failure.

The permissible connection pressure is max. 1.5 bar absolute.

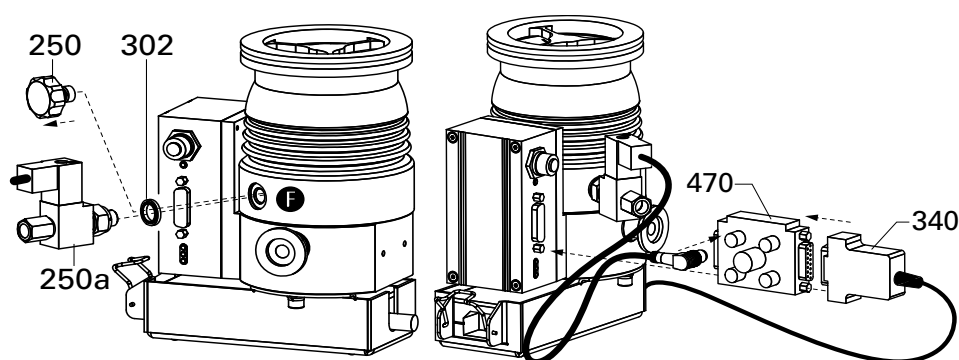

Fig. 8: Connecting the venting valve

250	Venting screw	302	Seal ring	470	Adapter TCS 12
250a	Venting valve	340	Connecting plug		

- Unscrew the venting screw from the venting connection of the turbopump.
- Screw in the venting valve with seal ring.
- Plug in and fix the accessory's control lead to a free connection port on the connecting cable or adapter of the electronic drive unit.
- Make the settings and control via the interfaces of the TC 110.

→ If necessary install a venting gas supply (e.g. inert gas) to the intake (G 1/8") of the solenoid valve.

Sealing gas connection

The turbopump must be operated with sealing gas to protect it, such as in the case of unclean processes or high gas loads. The supply is made via a sealing gas valve or alternatively via a sealing gas throttle without control. The activation of the control valve for the sealing gas connection is not pre-installed in the electronic drive unit and has to be configured via their interfaces.

The permissible connection pressure is max. 1.5 bar absolute.

- When operating the pump with more than 50 % of the maximum gas load, sealing gas must be used to ensure rotor cooling.
- The sealing gas flow rate depends on the pump and is 7.5 - 9.5 sccm for the Hi-Pace 80.

Sealing gas supply with control valve

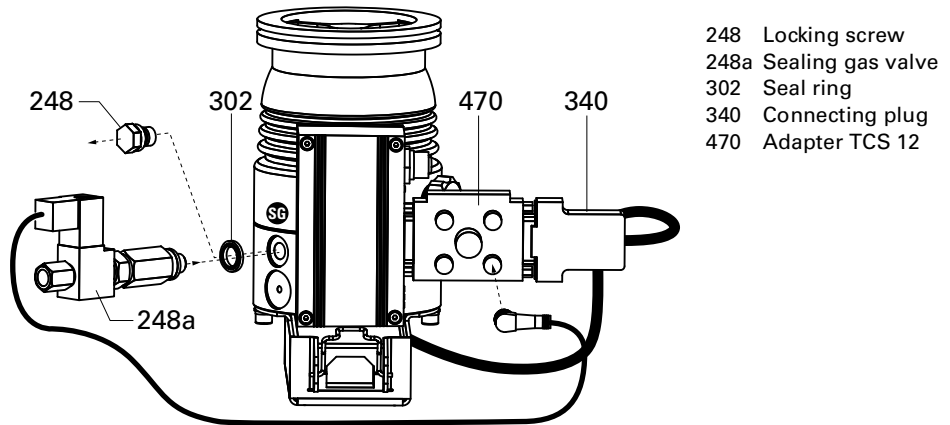

Fig. 9: Connecting the sealing gas valve

- Unscrew the screw plug with sealing ring out of the sealing gas connection of the turbopump.
- Screw the sealing gas valve with seal ring into the sealing gas connection.
- Plug in and fix the accessory's control lead to a free connection port on the connecting cable or adapter of the electronic drive unit.
- Make the settings and control via the interfaces of the TC 110.
- Install the sealing gas supply (e.g. inert gas) via a connection adapter or on the inlet side (G 1/8") of the control valve.

Sealing gas supply without control valve

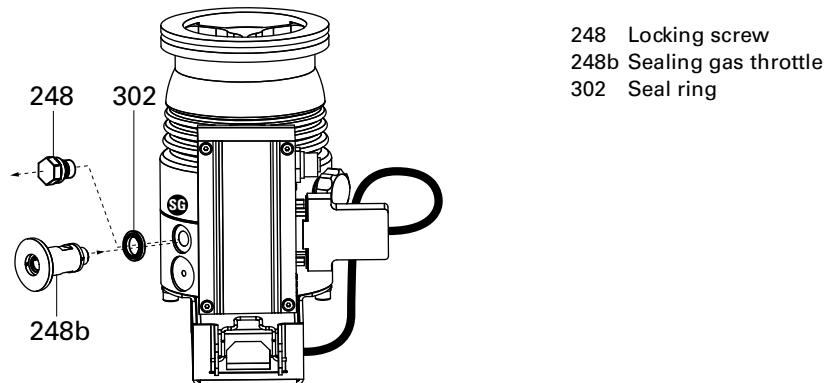

Fig. 10: Connecting the sealing gas throttle

- Unscrew the screw plug with sealing ring out of the sealing gas connection of the turbopump.
- Screw the sealing gas throttle with sealing ring into the sealing gas connection.

6 Operation

6.1 Commissioning

The following important settings are programmed in the electronic drive unit ex factory.

- Control max. run-up time: 8 min
- Gas mode: 0 = heavy gases
- Rotation speed switchpoint: 80% of the nominal rotation speed
- Venting rotation speed at delayed venting: 50% of the nominal rotation speed
- Venting time: 3600 s

- When sealing gas is used: Open the sealing gas supply and check the flow.
- Establish the mains for the power supply.



CAUTION

Danger of the pump being destroyed

Pumping of gases with the molecular mass > 39 in the wrong gas mode can lead to destruction of the pump.

- Ensure the gas mode is correctly set.
- Contact Pfeiffer Vacuum before using gases with a greater molecular mass (> 80).

Connecting the power supply

The turbopumps HiPace 80 form a single unit with the electronic drive unit and the power supply pack. The power supply is mounted to the pump and connected to the electronic drive unit ex factory. The valid supply voltage for the power supply amounts 90 - 265 VAC, 50/60 Hz.



WARNING

Danger of electric shock

In case of defect, the parts connected to the power supply are under voltage.

- Always keep the mains connection freely accessible so you can disconnect it at any time.



CAUTION

Automatic start

After setting up the mains supply, the turbopump with OPS 70 will run up immediately.

- Switch on the mains supply on the turbopump immediately before operation.

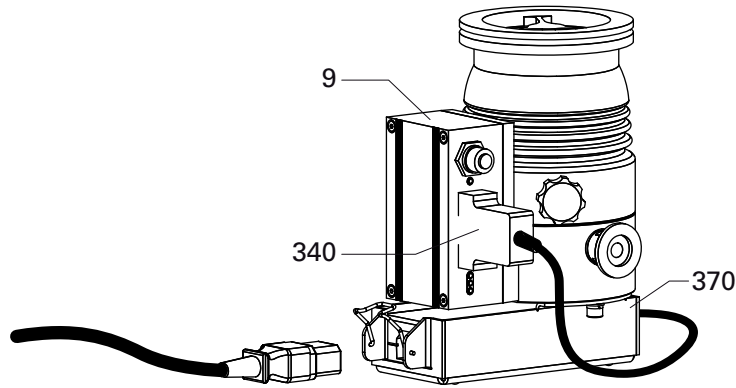

Fig. 11: Connecting the mains supply

9 Electronic drive unit TC 110 340 Connecting plug 370 Power supply OPS 70

- Order the mains cable separately (see "accessories").
- Insert the mains cable into the mains connection *AC in*.
- Lock the mains cable with the mounting bracket.
- Connect the mains cable to the mains.
- Always ensure a safe connection to the protective earthing conductor (PE, protection class I).

After the mains voltage is applied to the power supply, the TC 110 performs a self-test to check the supply voltage. The provided supply voltage for the TC 110 is 24 VDC ± 5% in accordance with standard EN 60 742. The turbopump is set into operation.

6.2 Operation modes

The following operation modes are available:

- Operation without operating unit
- Operation via RS485 and Pfeiffer Vacuum display and control units or PC
- Operation via field bus

6.3 Function description



WARNING

Danger due to open high vacuum flange

The rotor of the turbopump turns at high speed. If the high vacuum flange is open, there is a danger of cut injuries and that the pump can be destroyed by objects falling into it.

- Never operate the pump with an open high vacuum flange.

Operation without operating unit

- Switch on the pump by connecting the mains cable with the mains supply.

After operating voltage is applied, the TC 110 performs a self-test to check the supply voltage. Once the self test has been successfully completed on the TC 110 (approx. 10 seconds), the turbopump and the backing pump - if connected - begin to operate.

Operation with DCU or HPU

- Consider the following manuals for the operation via Pfeiffer Vacuum display and control units:
 - Operating instructions "DCU"
 - Operating instructions "HPU"

- Operating instructions "Electronic drive unit TC 110"
- Remove the bridges in the connecting plug via DIL switches S1 and S2.
- Connect the display and control unit to the plug "RS485" of the adapter or the connecting cable.
- Settings are possible via the RS485 by using DCU, HPU or PC.

Operation via field bus



Integrating and operating Pfeiffer Vacuum turbopumps in the customer's field bus system is possible for electronic drive units with a corresponding field bus panel.

- Consider the following manuals for the operation via field bus:
 - Operating instructions for the electronic drive unit with the respective connection panel

6.4 Monitoring of the operation conditions

Operating mode display via LED

LEDs in the front panel of the electronic drive unit show basic operating conditions of the turbopump. A differentiated malfunction and warning display is possible only for operation with DCU or HPU.

LED	Symbol	Steady OFF	Flashing (1/12 s active)	Blinking (1/2 s active)	Steady ON
Green		insufficient power supply	Pumping station "OFF" Rotation speed ≤ 1Hz	Pumping station "OFF" Rotation speed > 1 Hz	Pumping station "ON"
Yellow		no warning			Warning
Red		no malfunction			Malfunction

Temperature monitoring

The drive power is reduced in case of impermissible motor temperature or impermissibly high housing temperature. This can cause falling below the rotation speed switchpoint and so result in turning off the turbopump.

6.5 Switching off and venting

Switching off

After the turbopump is switched off, it must be vented to avoid contamination due to particles streaming back from the fore-vacuum area.

- Close the fore-vacuum line: Switch off the backing pump or close a fore-vacuum valve.
- Switch off the turbopump on the control unit or via remote control.
- Venting (possibilities, see below)

Venting

Manually Venting

- Open the venting screw (included) in the venting connection of the turbopump about one turn.

Venting with Pfeiffer Vacuum Venting Valve

- Enable venting via the functions of the electronic drive unit.
- Settings are possible via the RS485 by using DCU, HPU or PC.

Venting rotation speed	Switch off the pumping station	Mains power failure ¹⁾
50% of the nominal rotation speed	Venting valve opens for 3600 s (1 h, works setting)	Venting valve opens for 3600 s (1 h, works setting)

¹⁾When mains power is restored the venting procedure is aborted.

Basic information for the rapid venting

Venting of the vacuum chamber in two steps. Ask for details on individual solutions from Pfeiffer Vacuum.

- Vent for 20 seconds at a rate of pressure rise of max. 15 mbar/s.
 - The valve cross section for the venting rate of 15 mbar/s must be adapted to the size of the vacuum chamber.
 - For small vacuum chambers, use the Pfeiffer Vacuum venting valve.
- Then vent with an additional venting valve of any desired size.

7 Maintenance / replacement



WARNING

Contamination of parts and operating fluid by pumped media is possible.

Poisoning hazard through contact with materials that damage health.

- In the case of contamination, carry out appropriate safety precautions in order to prevent danger to health through dangerous substances.
- Decontaminate affected parts before carrying out maintenance work.



NOTE

Disclaimer of liability

Pfeiffer Vacuum accepts no liability for personal injury or material damage, losses or operating malfunctions due to improperly performed maintenance. The liability and warranty entitlement expires.

7.1 Maintenance intervals and responsibilities

- Clean the turbopump externally with a lint-free cloth and little industrial alcohol.
- Replace the operating fluid reservoir and electronic drive unit yourself.
- Change the operating fluid reservoir at least every 4 years.
- Change the turbopump bearing at least every 4 years.
 - Contact Pfeiffer Vacuum Service.
- Clarify shorter change intervals for extreme loads or impure processes with Pfeiffer Vacuum Service.
- For all other cleaning, maintenance or repair work, please contact your Pfeiffer Vacuum service location.

7.2 Replacing the integrated power supply

- Turn off the vacuum pump, vent to atmospheric pressure and allow to cool, if necessary.
- Remove the mains plug from the power supply.
- Remove the vacuum pump from the system, if necessary.
- Close the flange openings by using the original protective covers.

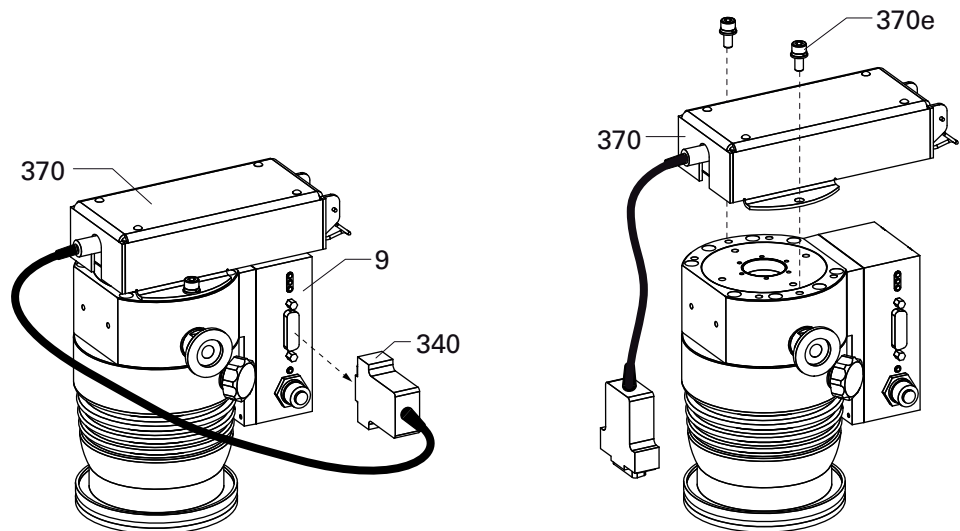

Fig. 12: Assembly / disassembly of the integrated power supply OPS 70

9	Electronic drive unit TC 110	370	Power supply OPS 70
340	Connecting plug	370e	Allen head screw

- Unscrew and remove the connecting plug 93 from the electronic drive unit.
- Turn the turbopump over onto the closed high vacuum flange.
- Unscrew the Allen head screws 370e of the fastening of the power supply.
- Remove the power supply from the pump.
- Installing of a integrable power supply in reversed order.

7.3 Replacing the operating fluid reservoir



WARNING

Poisoning hazard through contact with materials that damage health.

The operating fluid reservoir and parts of the pump may contain toxic substances from the pumped media.

- Dispose of operating fluid reservoir in accordance with the applicable regulations. Safety data sheet on request or under www.pfeiffer-vacuum.net
- Prevent health hazards or environmental damage due to contamination by means of appropriate safety precautions.
- Decontaminate affected parts before carrying out maintenance work.

- Turn off the vacuum pump, vent to atmospheric pressure and allow to cool, if necessary.
- Remove the vacuum pump from the system, if necessary.
- Close the flange openings by using the original protective covers.
- Turn the turbopump over onto the closed high vacuum flange.
- Disassemble the integrated power supply according to instructions.

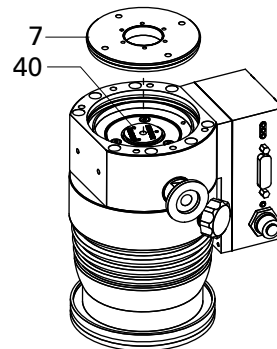
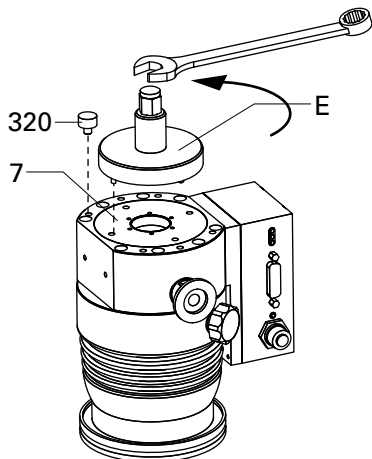

E Special tool (PV M40 813)
7 End cover

40 Operating fluid reservoir
320 Anti-vibration buffer

- Unscrew the anti-vibration buffers from the pump bottom part.
- Screw out the end cover on the bottom of the turbopump with special tool E. Pay attention to O-ring.

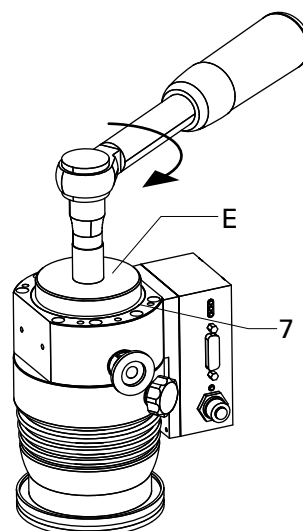
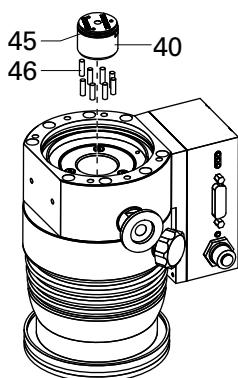

40 Operating fluid reservoir
45 O-ring

46 Porex rod

- Lift out the operating fluid reservoir using two screwdrivers.
- Using tweezers, pull out Porex rods (9 pieces).
- Remove impurities from the turbopump and the end cover with a clean, lint-free cloth. **Do not use any cleaning fluids!**
- Using tweezers, insert new Porex rods (9 pieces).
- Push the new operating fluid reservoir into the turbopump up to the O-ring.
- Screw in the end cover with O-ring. The operating fluid reservoir is brought into the correct axial position by the end cover.
- Observe the end cover's tightening torque **13 Nm ± 10 %**.
- Screw rubber-metal buffer into the pump bottom part.

7.4 Replacing the electronic drive unit

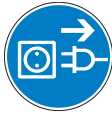

CAUTION

Damages to the pump and drive

Even after the mains power is switched off, the subsequently running pump delivers electric power to the electronic drive unit. There is a danger of electric body contact by premature separating the pump from the electronic drive unit.

- Never separate the electronic drive unit from the pump when the mains power is connected or the rotor is running.



NOTE

Operating parameters of the electronic drive unit

The factory operating parameters are always preset with replacement shipments.

- The use of a HPU enables the storing and the reuse of an existing parameter record.
- Reset any individually changed application parameters.
- Refer to the manual "Pumping operations".

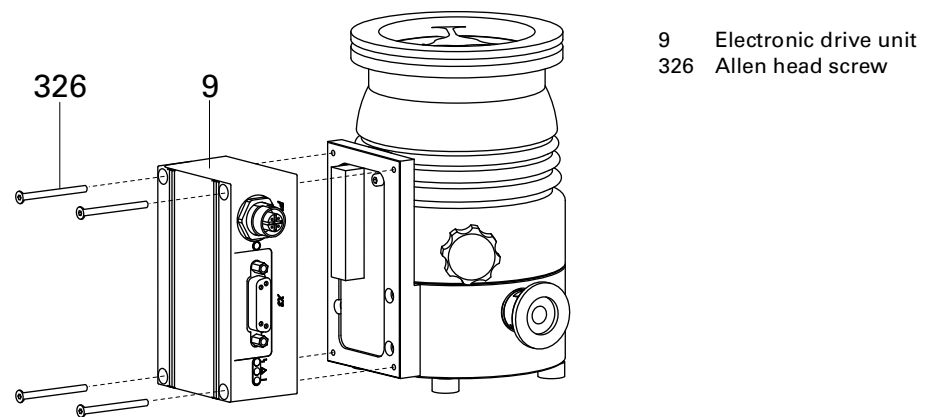

- 9 Electronic drive unit
- 326 Allen head screw

Fig. 13: Assembly / disassembly of the TC 110

- Do not exercise any mechanical load on the electronic drive unit.
- Turn off the vacuum pump, vent to atmospheric pressure and allow to cool, if necessary.
- Only separate the pump and the electronic drive unit from each other after disconnecting the supply voltage and the complete standstill of the pump.
- Remove the vacuum pump from the system, if necessary.
- Unscrew Allen head screws (4 x) from the electronic drive unit.
- Pull the electronic drive unit off the pump.
- Screw on and connect new electronic drive unit to the turbopump.

Rotation speed set value

The typical nominal rotation speed of a turbopump is factory-set in the electronic drive unit. If the electronic drive unit is replaced or a different pump type is used, the reference set value of the nominal rotation speed must be confirmed. This procedure is part of a redundant safety system for avoiding excess rotation speeds.

HiPace	Nominal rotation speed confirmation [P:777]
10 / 80	1500 Hz
300	1000 Hz

- Adjust the parameter [P:777] according to the pump type.

8 Decommissioning

8.1 Shutting down for longer periods



WARNING

Contamination of parts and operating fluid by pumped media is possible.

Poisoning hazard through contact with materials that damage health.

- In the case of contamination, carry out appropriate safety precautions in order to prevent danger to health through dangerous substances.
- Decontaminate affected parts before carrying out maintenance work.

If the turbopump should be shut down for longer than a year:

- Remove the vacuum pump from the system, if necessary.
- Change the operating fluid reservoir.
- Close the high vacuum flange of the turbopump.
- Evacuate turbopump via the fore-vacuum flange.
- Vent turbopump via the venting connection with dry air or inert gas.
- Close the flange openings by using the original protective covers.
- Close further connection ports by using the corresponding protective covers.
- Place pump upright on rubber feet.
- Store the pump only indoors at temperatures between -25 °C and +55 °C.
- In rooms with moist or aggressive atmospheres, the pump must be airproof shrink-wrapped in a plastic bag together with a bag of desiccant.

8.2 Re-starting



CAUTION

Re-starting

The serviceability of the operating fluid of the turbopump without operation is a maximum of 4 years. Before restarting after a shut-down of **4 years or longer**, carry out the following work:

- Replace the operating fluid reservoir
 - Replace bearings
 - Follow the maintenance instructions and inform Pfeiffer Vacuum
- Check turbopump for contamination and moisture.
 - Clean the turbopump externally with a lint-free cloth and little industrial alcohol.
 - If necessary, have Pfeiffer Vacuum Service clean the turbopump completely.
 - If necessary, have the bearings replaced. Take into account the total running time.
 - Change the operating fluid reservoir.
 - Installation and commissioning in accordance with the operating instructions.

8.3 Disposal

Products or parts thereof (mechanical and electrical components, operating fluids, etc.) may cause environmental burden.

- Safely dispose of the materials according to the locally applicable regulations.

9 Malfunctions

Please note the following instructions should the pump malfunction:

9.1 Rectifying malfunctions

Problem	Possible causes	Remedy
Pump will not start; non of the built-in LEDs on the TC 110 lights up	• Electrical supply interrupted	⇒ Check plug contacts on the power supply ⇒ Check supply lines on the power supply ⇒ Check the output voltage (24 VDC) on the connection "DC out" of the power supply ⇒ Check the plug contacts on the TC
	• Operating voltage incorrect	⇒ Apply correct operating voltage ⇒ Observe the rating plate
	• No operating voltage applied	⇒ Apply operating voltage
	• TC 110 defective	⇒ Exchange the TC 110 ⇒ Contact the Pfeiffer Vacuum Service
	• Integrated power supply defective	⇒ Replace the integrated power supply.
Pump will not start; green LED on the TC 110 is flashing	• At operation without operating unit: DIL switches on the connecting plug of the integrated power supply are in the wrong position	⇒ Close the bridges in the connecting plug using the DIL switches
	• At operation via RS485: DIL switches on the connecting plug of the integrated power supply are in the wrong position	⇒ Remove the bridges in the connecting plug using the DIL switches
	• Voltage drop in the cable too high	⇒ Use a suitable cable
Pump does not attain the final rotational speed within the specified run-up time	• Fore-vacuum pressure too high	⇒ Ensure function and suitability of the backing pump
	• Leak	⇒ Perform leak detection ⇒ Check sealings and flange fastenings ⇒ Eliminate leaks
	• Gas load too high	⇒ Prozessgaszufuhr reduzieren
	• Rotor runs hard, bearing defective	⇒ Check the bearing for noises ⇒ Contact the Pfeiffer Vacuum Service
	• Setpoint for run-up time to low	⇒ Extend the run-up time via DCU, HPU or PC
Pump does not attain the ultimate pressure	• Thermal overload: – Lack of air ventilation – Fore-vacuum pressure too high – Ambient temperature too high	⇒ Reduce thermal loads – Ensure adequate cooling – Lower the fore-vacuum pressure – Adjust ambient conditions
	• Pump is dirty	⇒ Bake out the pump ⇒ Cleaning in case of heavy contamination – Contact the Pfeiffer Vacuum Service
Unusual noises during operation	• Vacuum chamber, pipes or pump are leaky	⇒ Leak detection starting from the vacuum chamber ⇒ Eliminate leaks
	• Bearing damage	⇒ Contact the Pfeiffer Vacuum Service
	• Rotor damage	⇒ Contact the Pfeiffer Vacuum Service
Red LED on the TC 110 is on	• Splinter shield or protective screen are loose	⇒ Correct the seat of the splinter shield or the protective screen ⇒ Observe the installation notes
Pump will not start; non of the built-in LEDs on the TC 110 lights up	• Collective fault	⇒ Reset by switching the mains OFF/ON ⇒ Differentiated malfunction display is possible via DCU or HPU ¹⁾ ⇒ Contact the Pfeiffer Vacuum Service

¹⁾If no display and control unit is available, please contact the Pfeiffer Vacuum Service.

10 Service

Pfeiffer Vacuum offers first-class service!

- Operating fluid and bearing change on the spot by Pfeiffer Vacuum FieldService
- Maintenance / repair in the nearby ServiceCenter or ServicePoint
- Fast replacement with exchange products in mint condition
- Advice on the most cost-efficient and quickest solution

Detailed information, addresses and forms at: **www.pfeiffer-vacuum.net** (**Service**).

Maintenance and repair in the Pfeiffer Vacuum ServiceCenter

The following steps are necessary to ensure a fast, smooth servicing process:

- Download the forms "Service Request" and "Declaration on Contamination".¹⁾
- Fill out the "Service Request" form and send it by fax or e-mail to your Pfeiffer Vacuum service address.
- Include the confirmation on the service request from Pfeiffer Vacuum with your shipment.
- Fill out the declaration on contamination and include it in the shipment (required!).
- Dismantle all accessories.
- Drain the operating fluid (applies for turbopumps with pumping speed > 700 l/s).
- Leave electronic drive on the pump.
- Close the flange openings by using the original protective covers.
- If possible, send pump or unit in the original packaging.

Sending of contaminated pumps or devices

No units will be accepted if they are contaminated with micro-biological, explosive or radioactive substances. "Hazardous substances" are substances and compounds in accordance with the hazardous goods directive (current version). If pumps are contaminated or the declaration on contamination is missing, Pfeiffer Vacuum performs decontamination at the shipper's expense.

- Neutralise the pump by flushing it with nitrogen or dry air.
- Close all openings airtight.
- Seal the pump or unit in suitable protective film.
- Return the pump/unit only in a suitable and sturdy transport container and send it in while following applicable transport conditions.

Exchange unit

The factory operating parameters are always preset with exchange units. If you use changed parameters for your application, you have to set these again.

Service orders

All service orders are carried out exclusively according to our repair conditions for vacuum units and components.

¹⁾ Forms under www.pfeiffer-vacuum.net

11 Spare parts HiPace 80

Item	Designation	Size	Order number	Notes	Pieces	Order qty
9	Electronic drive unit TC 110		according to the rating plate	depends on the connection panel	1	
40	Operating fluid reservoir		PM 143 740 -T	incl. Porex rods	1	
370	Power supply OPS 70		PM 061 967 -X	incl. connecting plug 340	1	

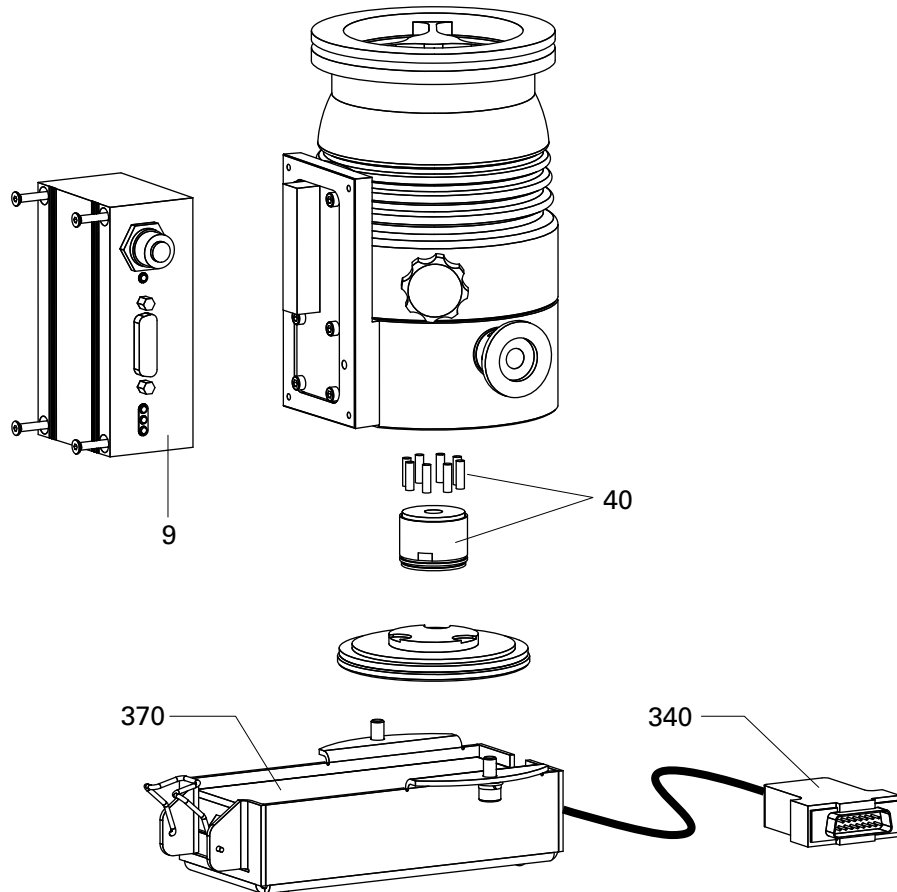

Please also specify model number of the the rating plate when ordering accessories or spare parts.

12 Accessories

Designation	HiPace™ 80 with TC 110 and power supply OPS 70 DN 63 ISO-K	HiPace™ 80 with TC 110 and power supply OPS 70 DN 63 CF-F	HiPace™ 80 with TC 110 and power supply OPS 70 DN 40 ISO-KF	Order quantity
Power supplies and control units				
DCU 002, Display control unit	PM 061 348-T	PM 061 348-T	PM 061 348-T	
HPU 001, handheld programming unit	PM 051 510-T	PM 051 510-T	PM 051 510-T	
Accessories package for HPU - Power supply, software and PC cable	PM 061 005-T	PM 061 005-T	PM 061 005-T	
Cables				
230 V AC mains cable with Euro-style safety plug, IEC power socket (straight), 3 m	P 4564 309 ZA	P 4564 309 ZA	P 4564 309 ZA	
115 V AC mains cable with UL plug, IEC power socket (straight), 3 m	P 4564 309 ZE	P 4564 309 ZE	P 4564 309 ZE	
208 V AC mains cable with UL plug, 3 m	P 4564 309 ZF	P 4564 309 ZF	P 4564 309 ZF	
Accessories for venting				
24 V DC venting valve, G 1/8", for connection to TC 110	PM Z01 290	PM Z01 290	PM Z01 290	
Venting flange DN 10 KF-G1/8"	PM 033 737 -T	PM 033 737 -T	PM 033 737 -T	
TTV 001, air drier for venting turbopumps	PM Z00 121	PM Z00 121	PM Z00 121	
Accessories for cooling				
Air cooling for HiPace 80 with TC 110, plug M8	PM Z01 300	PM Z01 300	PM Z01 300	
Backing pump control				
Backing pump relay box, single phase 5 A, for TC 110/TCP 350	PM 061 372-T	PM 061 372-T	PM 061 372-T	
Backing pump relay box, single phase 20 A, for TC 110/TCP 350	PM 061 373-T	PM 061 373-T	PM 061 373-T	
TVV 001 fore-vacuum safety valve, 230 V AC	PM Z01 205	PM Z01 205	PM Z01 205	
TVV 001 fore-vacuum safety valve, 115 V AC	PM Z01 206	PM Z01 206	PM Z01 206	
Control cable 3/2 pole, TC 100 - MVP, 0,5 m	PM 061 433 -x			
Mounting kits				
Mounting kit for HiPace 80, DN 63 ISO-K, including coated centering ring, bracket screws	PM 016 360-T			
Mounting kit for HiPace 80, DN 63 ISO-K, including coated centering ring, protection screen, clamping screws	PM 016 362-T			
Mounting kit for HiPace 80, DN 63 ISO-K, including coated centering ring, splinter shield, bracket screws	PM 016 361-T			
Mounting kit for HiPace 80, DN 63 ISO-K to DN 63 ISO-F, including coated centering ring, claws	PM 016 510-T			
Mounting kit for HiPace 80, DN 63 ISO-K to DN 63 ISO-F, including coating centering ring, protection screen, claws	PM 016 512-T			
Mounting kit for HiPace 80, DN 63 ISO-K to DN 63 ISO-F, including coated centering ring, splinter and claws	PM 016 511-T			
Set of hexagon bolts, 8 count, M8, DN 63 CF		PM 016 683-T		
Set of stud screws, 8 count, M8, DN 63 CF		PM 016 684-T		
Mounting kit for HiPace 80, DN 40 ISO-KF, including centering ring and clamping ring			PM 016 625-T	

Designation	HiPace™ 80 with TC 110 and power supply OPS 70 DN 63 ISO-K	HiPace™ 80 with TC 110 and power supply OPS 70 DN 63 CF-F	HiPace™ 80 with TC 110 and power supply OPS 70 DN 40 ISO-KF	Order quantity
Mounting kit for HiPace 80, DN 40 ISO-KF, splinter shield, clamping ring			PM 016 626-T	
Miscellaneous accessories				
Sealing gas valve for HiPace 80	PM Z01 310	PM Z01 310	PM Z01 310	
Sealing gas throttle for HiPace 80	PM Z01 316	PM Z01 316	PM Z01 316	
Centering ring, with multifunction coating, DN 63 ISO-K/-F	PM 016 206-U			
Centering ring, with multifunction coating and integrated protection screen, DN 63 ISO-K/-F	PM 016 208-U			
Centering ring, with multifunction coating and integrated splinter shield, DN 63 ISO-K/-F	PM 016 207-U			
Protection screen, DN 63 CF-F		PM 016 333		
Splinter screen for Turbopumps, DN 63 CF-F flange		PM 016 312		
Centering ring, FPM/Aluminium, DN 40 ISO-KF			PF 110 140-T	
Centering ring, with integrated mesh screen, DN 40 ISO-KF			PF 113 240-T	
Centering ring, with integrated splinter shield, DN 40 ISO-KF			PM 006 375-X	
Clamping ring clip DN 10-16 ISO-KF	PF 102 016-T			
Vibration damper for HiPace 80, DN 63 ISO-K	PM 006 800-X			
Vibration damper for HiPace 80, DN 63 CF-F		PM 006 801-X		
Vibration damper for HiPace 80, DN 40 ISO-KF			PM 006 799-X	
USB converter to RS-485 interface	PM 061 207-T	PM 061 207-T	PM 061 207-T	
Interface cable, 3 m, M 12	PM 061 283-T	PM 061 283-T	PM 061 283-T	
Interface cable RS-485, 3 m, M12, straight, 90°	PM 061 791 -T	PM 061 791 -T	PM 061 791 -T	
Y-Connector M12 to RS-485	P 4723 010	P 4723 010	P 4723 010	
Connection cable, plug M12, RJ 45	PM 051 726-T	PM 051 726-T	PM 051 726-T	
TCS 11, adapter for TC 110 with interface RS-485	PM 061 636 -U	PM 061 636 -U	PM 061 636 -U	
TCS 12, adapter for TC 110 with interface RS-485 and 4 accessory ports	PM 061 638-U	PM 061 638-U	PM 061 638-U	
TCS 13, adapter for TC 110 with interface RS-485 and 2 accessory ports	PM 061 856 -U	PM 061 856 -U	PM 061 856 -U	

13 Technical data and dimensions

13.1 General

Basic principles for the Technical Data of Pfeiffer Vacuum Turbopumps:

- Recommendations of PNEUROP committee PN5
- ISO 21360; 2007: "Vacuum technology - Standard methods for measuring vacuum-pump performance - General description"
- ISO 5302; 2003: "Vacuum technology - Turbomolecular pumps - Measurement of performance characteristics"
- Ultimate pressure: using a test dome and a 48 hrs. period of baking out
- Integral leak rate: using a Helium concentration of 100 %, period 10 s
- Acoustic pressure: Distance 1 m to the pump

13.2 Technical data

Parameter	HiPace™ 80	HiPace™ 80	HiPace™ 80
Flange (in)	DN 63 ISO-K	DN 63 CF-F	DN 40 ISO-KF
Flange (out)	DN 16 ISO-KF	DN 16 ISO-KF	DN 16 ISO-KF
Venting connection	G 1/8"	G 1/8"	G 1/4"
Rotation speed ±2%	90000 rpm	90000 rpm	90000 rpm
Run-up time	1.9 min	1.9 min	1.9 min
Pumping speed for N ₂	67 l/s	67 l/s	35 l/s
Pumping speed for He	58 l/s	58 l/s	41 l/s
Pumping speed for H ₂	48 l/s	48 l/s	38 l/s
Pumping speed for Ar	66 l/s	66 l/s	30 l/s
Pumping speed for CF ₄	54 l/s	54 l/s	25 l/s
Gas throughput at full rotational speed for N ₂	0.7 mbar l/s	0.7 mbar l/s	0.7 mbar l/s
Gas throughput at full rotational speed for He	2.3 mbar l/s	2.3 mbar l/s	2.3 mbar l/s
Gas throughput at full rotational speed for H ₂	8.9 mbar l/s	8.9 mbar l/s	8.9 mbar l/s
Gas throughput at full rotational speed for Ar	0.37 mbar l/s	0.37 mbar l/s	0.37 mbar l/s
Compression ratio for N ₂	> 1·10 ¹¹	> 1·10 ¹¹	> 1·10 ¹¹
Compression ratio for He	2·10 ⁷	2·10 ⁷	2·10 ⁷
Compression ratio for H ₂	1.3·10 ⁵	1.3·10 ⁵	1.3·10 ⁵
Compression ratio for Ar	> 1·10 ¹¹	> 1·10 ¹¹	> 1·10 ¹¹
Compression ratio for CF ₄	> 1·10 ¹¹	> 1·10 ¹¹	> 1·10 ¹¹
Fore Vacuum max. for N ₂	19 mbar	19 mbar	19 mbar
Fore Vacuum max. for He	19 mbar	19 mbar	19 mbar
Fore Vacuum max. for H ₂	14 mbar	14 mbar	14 mbar
Fore Vacuum max. for Ar	20 mbar	20 mbar	20 mbar
Fore Vacuum max. for CF ₄	18 mbar	18 mbar	18 mbar
Ultimate pressure with OnTool™ DryPump	1·10 ⁻⁷ mbar	1·10 ⁻⁸ mbar	1·10 ⁻⁷ mbar
Cooling method, standard	Convection	Convection	Convection
Cooling method, optional	Air	Air	Air
Cooling water temperature	5-25 °C	5-25 °C	5-25 °C
Cooling water consumption	75 l/h	75 l/h	75 l/h
Integral leak rate	2·10 ⁻⁸ mbar l/s	2·10 ⁻⁸ mbar l/s	2·10 ⁻⁸ mbar l/s
Operating voltage	24 ± 5 % V DC	24 ± 5 % V DC	24 ± 5 % V DC
Operating voltage power supply	90-264 V AC	90-264 V AC	90-264 V AC
Current consumption max	3 A	3 A	3 A
Power consumption max.	62 W	62 W	62 W
Sound pressure level	48 dB (A)	48 dB (A)	48 dB (A)
Interfaces	RS-485, Remote	RS-485, Remote	RS-485, Remote
Protection category	IP 30	IP 30	IP 30
Permissible magnetic field max.	3.3 mT	3.3 mT	3.3 mT
Relative humidity of air	5-85, non condensing %	5-85, non condensing %	5-85, non condensing %
Weight	2.9 kg	4.3 kg	2.87 kg

13.3 Dimensions

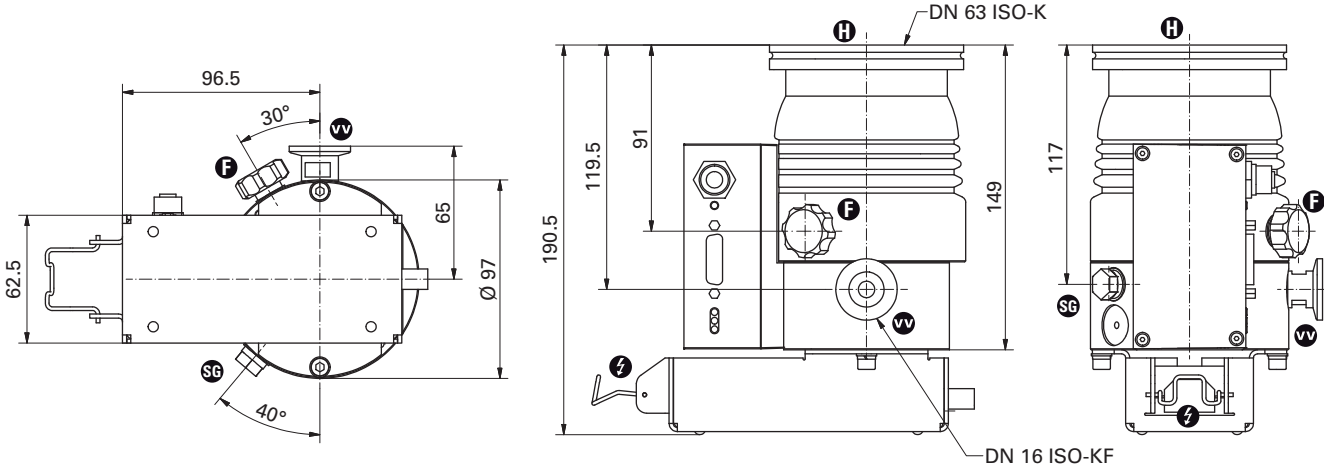

Fig. 14: HiPace 80, DN 63 ISO-K

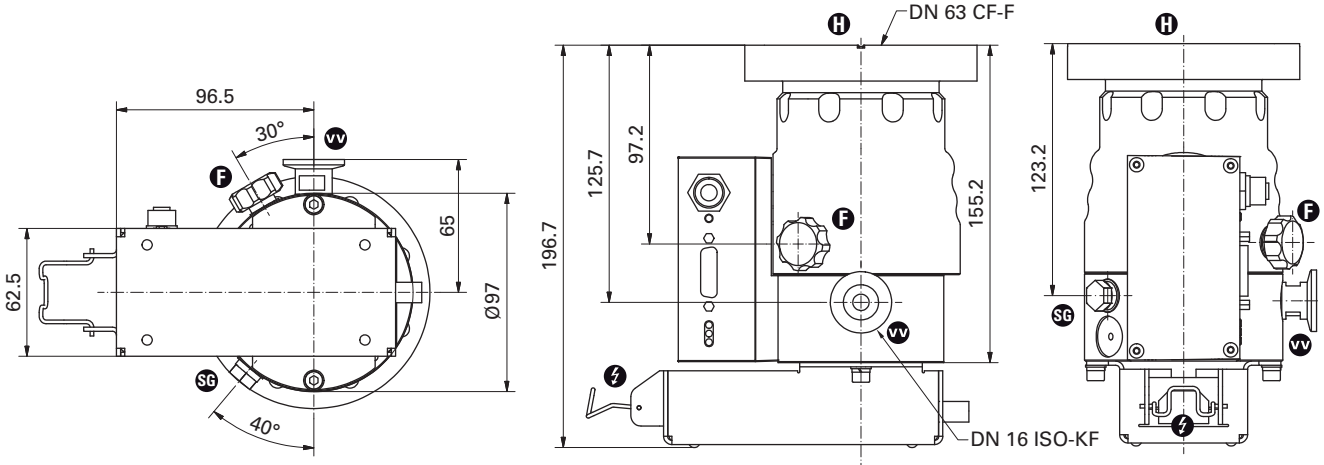

Fig. 15: HiPace 80, DN 63 CF-F

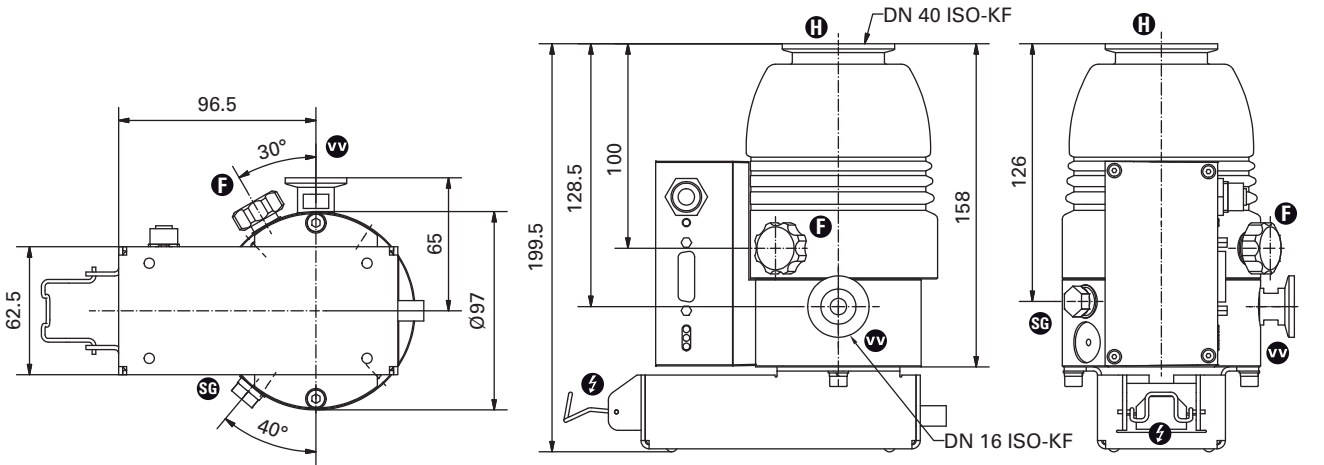

Fig. 16: HiPace 80, DN 40 ISO-KF



Manufacturer's Declaration

pursuant to the following EU directives:

- **Machinery 98/37/EEC (Annex II B)**
- **Electromagnetic Compatibility 2004/108/EC**
- **Low Voltage 2006/95/EEC**

We hereby certify that the product specified below is intended for installation in a machine which is forbidden to be put into operation until such time as it has been determined that the end product is in accordance with the provision of EU Directive 98/37/EEC.

The product specified below is in correspondence to the EU directives Machinery **98/37/EEC**, Electromagnetic Compatibility **2004/108/EEC** and Low Voltage **2006/95/EEC**.

HiPace 80

Guidelines, harmonised standards and national standards in languages and specifications which have been applied:

EN 294

EN 1012-2

EN 12100-1

EN 12100-2

EN 61010

Signatures:

Pfeiffer Vacuum GmbH
Berliner Straße 43
35614 Asslar
Germany

(M. Bender)
Managing Director

(Dr. M. Wiemer)
Managing Director

CE/2007

Vacuum is nothing, but everything to us!



Turbopumps



Rotary vane pumps



Roots pumps



Dry compressing pumps



Leak detectors



Valves



Components and feedthroughs



Vacuum measurement



Gas analysis



System engineering



Service

PFEIFFER  **VACUUM**

Pfeiffer Vacuum Technology AG · Headquarters/Germany

Tel. +49-(0) 64 41-8 02-0 · Fax +49-(0) 64 41-8 02-2 02 · info@pfeiffer-vacuum.de · www.pfeiffer-vacuum.net